



Application Notes for the VMS and GBTS

Application Notes for the VMS and GBTS

1. The VMS: Includes three major parts which are:

Cell voltage monitor with warning buzzer, over-high, and over-low signal outputs.

Balance during charging, referring to cell-voltages, compensated by historical records.

Digital interface able to communicate with the GBTS, diagnostic PC, dedicated charger, and power controller.

The VMS is built in functions of the cell voltage monitor, balance during charging, and digital interface. The digital interface of the VMS includes signals of OVP (over voltage protection, OVP/OHV), LVP (low voltage protection, LVP/OLV), and UART interface. This UART interface is used to communicate with the GBTS or the diagnostic PC, and it is allowable to be directly serially connected.

The balance criterion used in this VMS is comprehensive to deal with all of possible cell-statuses. And its target to make sure all cells controlled by this VMS to be fully charged at same time.

- a. Voltage level signals which are located on the topside of battery pack. There are 4pcs of LEDs used as the pack voltage indicator. Normally, the last led, green one, and shall be turned on under wake-up condition. If not, please charge your battery pack as soon as possible.

Pack Voltage $V > 13.2V$	● ● ● ●
Pack Voltage $12.6V < V < 13.2V$	● ● ●
Pack Voltage $12.0V < V < 12.6V$	● ●



Application Notes for the VMS and GBTS

Pack Voltage $11.4V < V < 12.0V$ ●

Pack Voltage $< 11.4V$

b. Warning Buzzer:

- Buzzer noise 3 times in long cycle: which is to notice the battery cell voltage is close to the limited-operating voltage (up voltage or low voltage).
- Buzzer noise in short cycle until battery energy is pretty low: Battery cell voltage is over the normal operation condition (fully charged or fully discharged). Please cut-off outer power connector as soon as possible, whether it is the charger, or power controller. Under such condition, there is one of over/low signal output. If your system takes those two signals to control your charger or power controller, your charger or power controller shall cut off automatically.

c. Over/low voltage signals:

- As your battery voltage is fully charged, the OVP (OHV) led is turned on your battery pack. If the OVP (OHV) led is turned on and your charger still works, please manually cut off your charger, and contact your charger provider.
- As your battery voltage is fully discharged, the LVP (OLV) led is turned on your battery pack. If the LVP (OLV) led is turned on and your power controller still works, please manually cut off your power controller, and contact your controller provider.
- They are signal-level. Current driving capacity I_{OH} : 5mA, I_{OL} : 1mA, V_{OH} : 4.2V, V_{OL} : 0.2V



Application Notes for the VMS and GBTS

- OLV(LVP): is used to shut down the vehicle controller. As the OLV is high, that warns the cell voltage is too low. Therefore, the vehicle controller shall shut down to prevent the battery from over-discharging risk.
- OHV(OVP): is used to cut-off the charger. As the OHV is high, that warns the cell voltage is too high. Therefore, the charge shall cut-off the output to prevent the battery from over-charging risk. Please note the OHV is a signal only. The OHV is not able to drive a relay. But you may use this signal to drive a photo-coupler, photo-MOSFET.



Application Notes for the VMS and GBTS

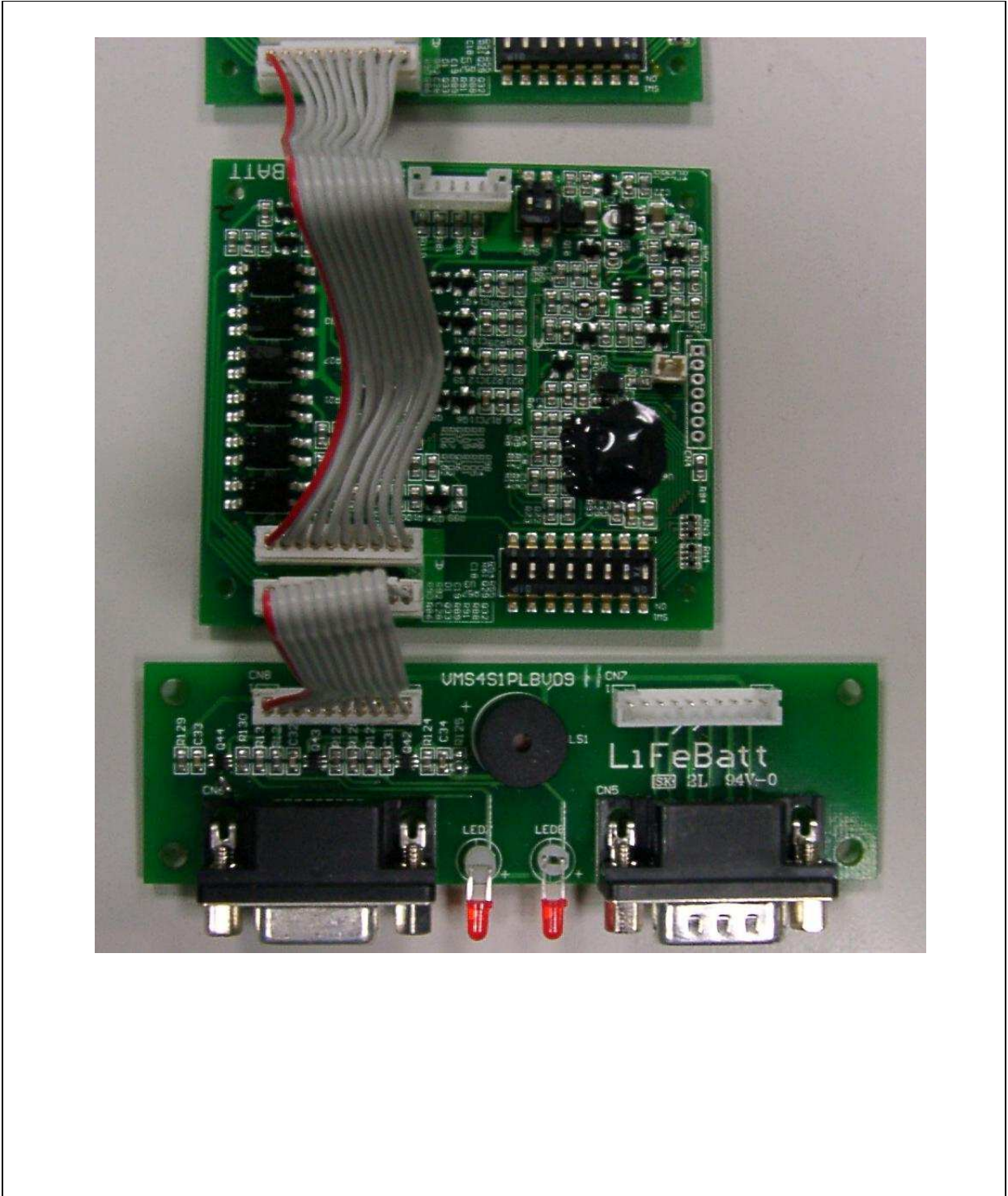



Application Notes for the VMS and GBTS

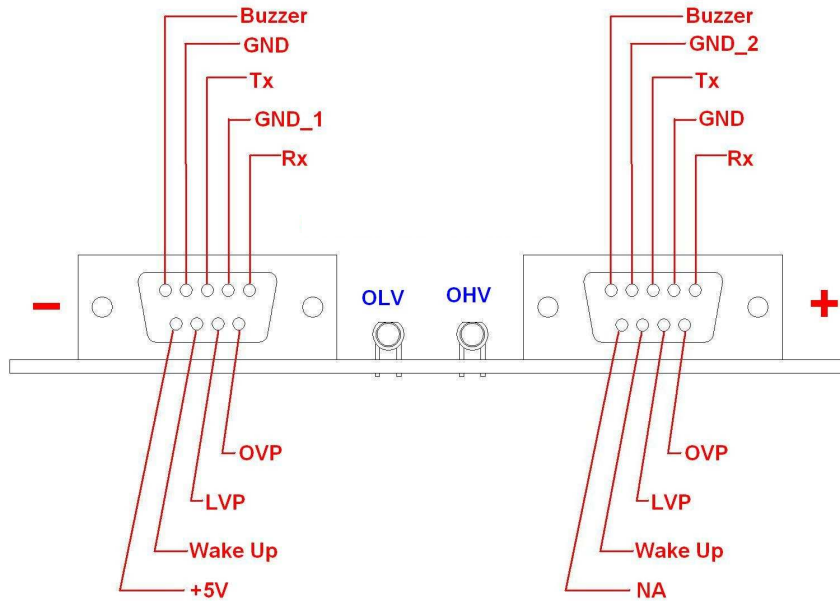

- Example as the VMS used in power pack of 80V/80Ah.



Application Notes for the VMS and GBTS

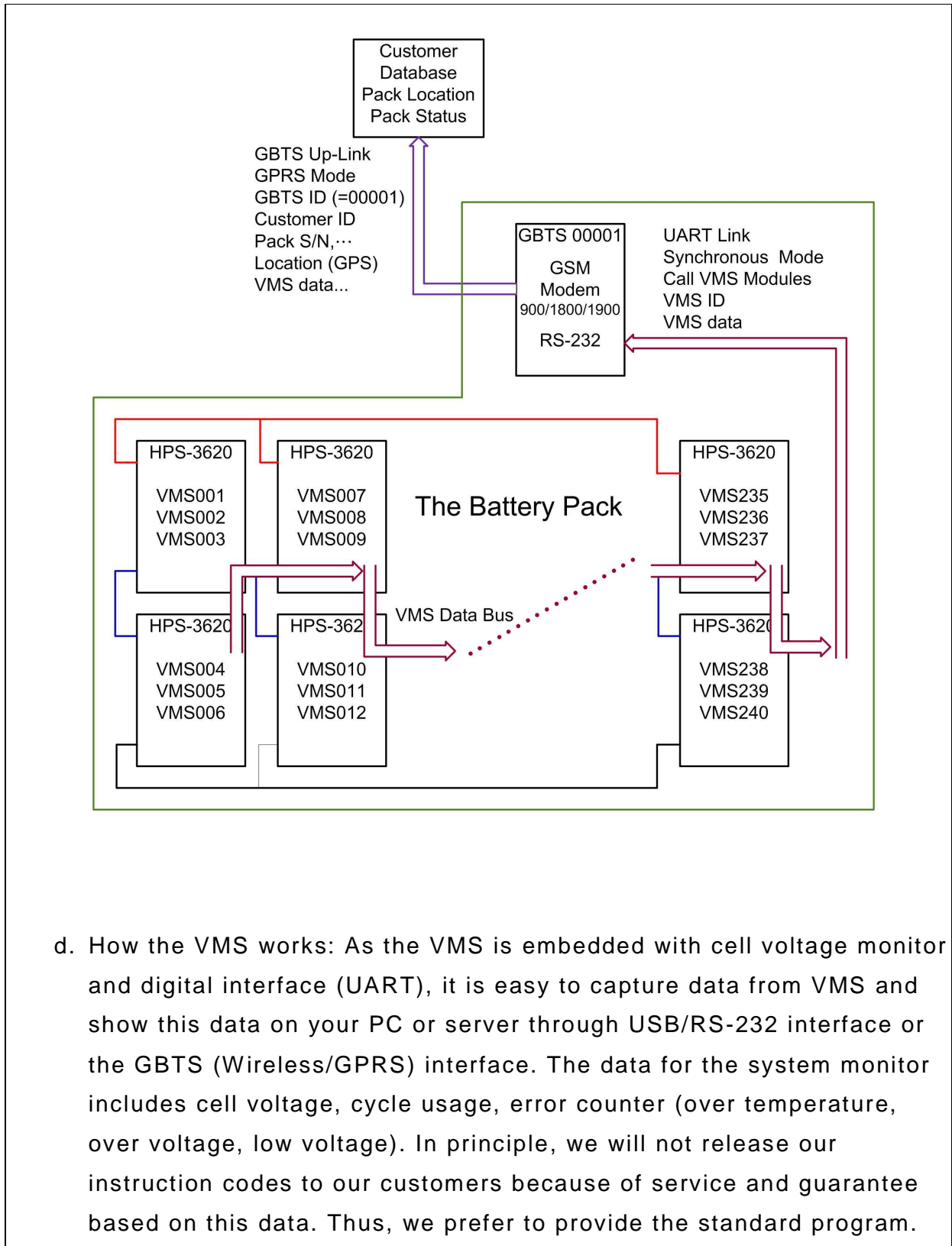



Application Notes for the VMS and GBTS

The following figure shows the diagnostic program on Window 2K/XP.

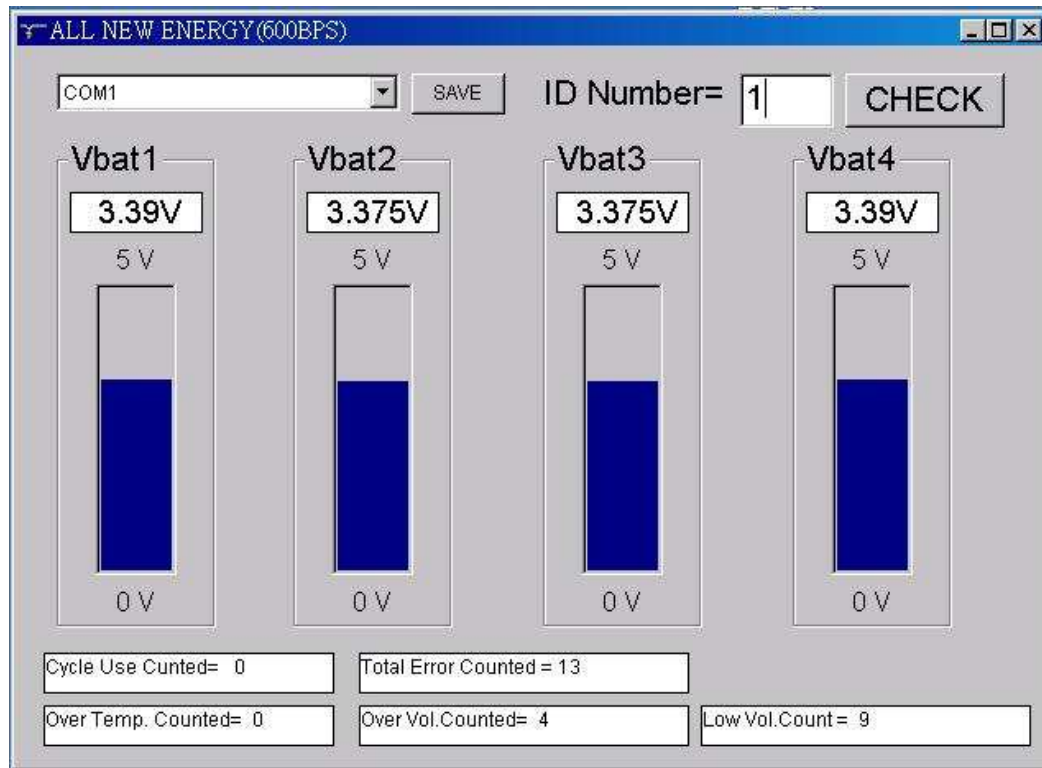

2. The GBTS: includes three major components, Which are

GPRS (GSM modem) to communicate the network through the GPRS (General Packet Radio Service) channel (the digital protocol of the GSM mobile phone).

WinCE core to provide real-time-operation-system, and the interface to the VMS.

GPS (Global positioning system) module to identify the GBTS location. (Optional)



Application Notes for the VMS and GBTS

a. Therefore, the GBTS is able to do the following tasks:

- Global positioning: may be used as the data of the handling or security control. (Optional)
- Sub-pack information: the service center is easy to control the pack status, and the information includes cycle use and all of abuse records (over high voltage, over low voltage, over operation temperature).
- The data is transferred through GPRS. That means the current system only works within the radiation range of the GSM cell station. (CDMA system will be added later.)
- The service server allows our customer to access the GBTS system. After the GBTS gets the request from the service server, the GBTS will poll the VMS of each sub-pack, and feedback the current data to the service server.

b. How the GBTS works:

- Each GBTS has a unique ID code.
- Each High Power Series (HPS) battery module contains it's own Voltage Monitoring System (VMS).
- Using serial UART port, the VMS of each HPS battery module is connected to the GBTS controller.
- The GBTS controller, using GPRS, sends a battery Status Record, every 12 hours to our data centre about the condition of each cell it is attached too.



Application Notes for the VMS and GBTS

- Each Status Record includes the number of cycles, vehicle position and error codes.
- Should an error be recorded, our administrator will then take appropriate action. That may be an email to advise the vehicle owner that the battery needs a service, or a phone call or SMS to advise the driver that the vehicle should be stopped immediately, in extreme circumstances.

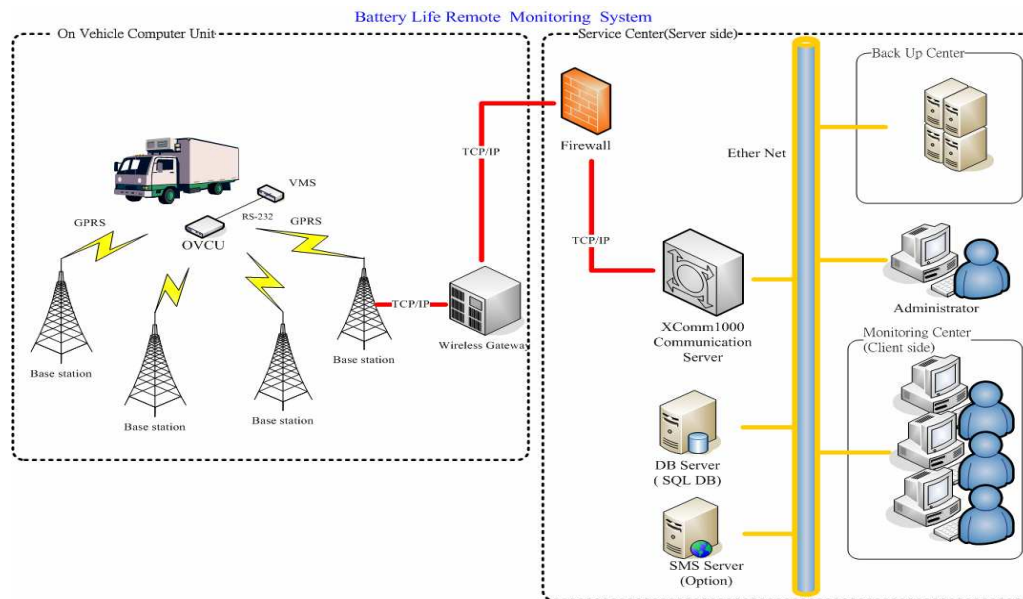

With GBTS we are able to pre-empt service requirements, notifying the vehicle owner of any potential problems even before the vehicle performance is impaired. This will also allow the vehicle owner to plan the vehicle service schedule.



Application Notes for the VMS and GBTS

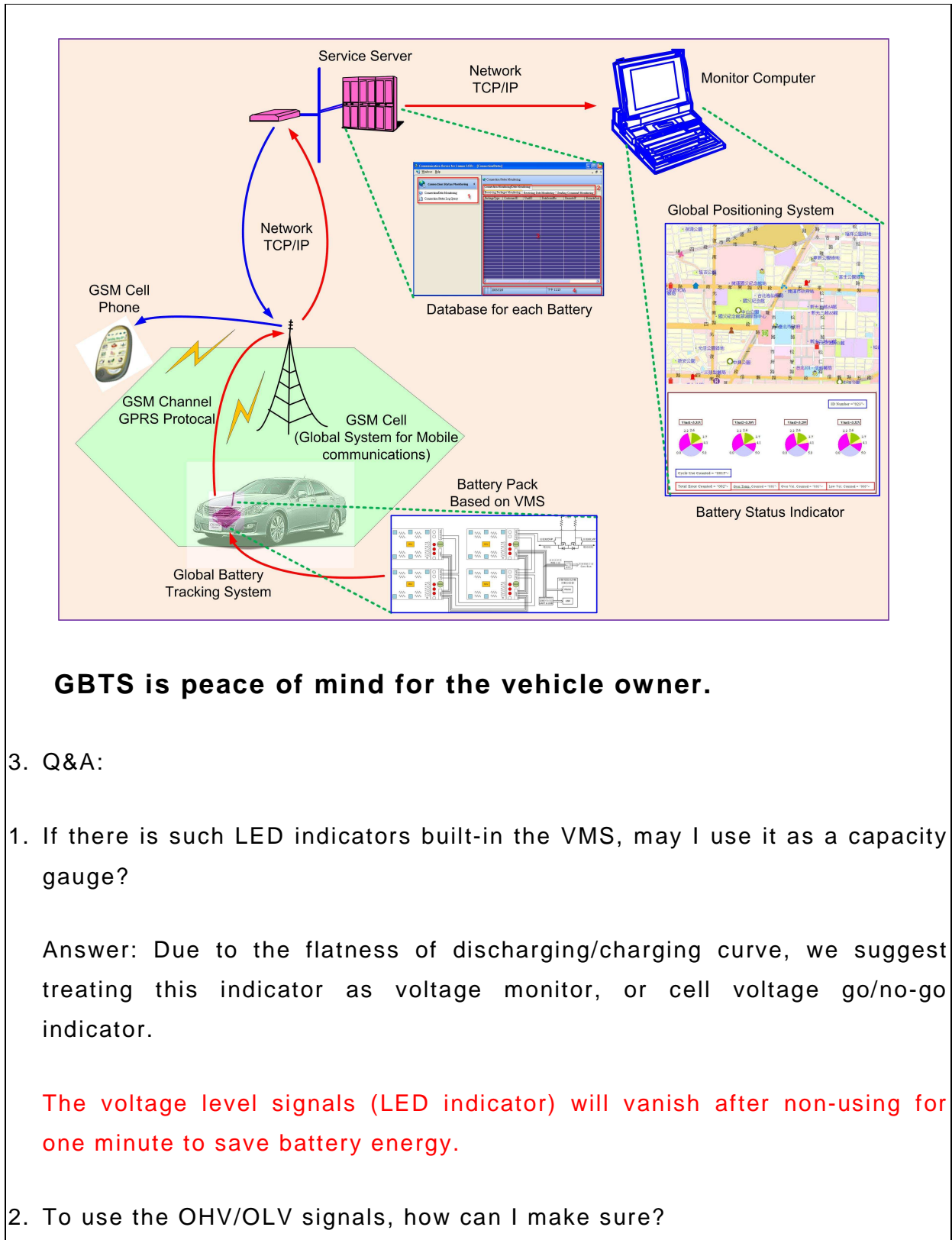

GBTS is peace of mind for the vehicle owner.

3. Q&A:

1. If there is such LED indicators built-in the VMS, may I use it as a capacity gauge?

Answer: Due to the flatness of discharging/charging curve, we suggest treating this indicator as voltage monitor, or cell voltage go/no-go indicator.

The voltage level signals (LED indicator) will vanish after non-using for one minute to save battery energy.

2. To use the OHV/OLV signals, how can I make sure?



Application Notes for the VMS and GBTS

Answer: Please only use the certified charger or power controller by LiFe Batt. Otherwise, you will lose your warranty from LiFeBATT. Also we will not be responsible for battery safety.

3. Why there are such errors counted in your system?

Answer: Because we are proud of our products, and we are able to provide 3 years' warranty to our customers. Therefore, we need to make sure our products are free from abuse.

Any extreme battery voltage during guaranteed life will be recorded in our VMS record. We reserve the limited service, if there is any extreme condition recorded. So-called extreme battery condition is impossible to happen, if LiFeBATT certifies your charger and power controller.

4. Should I keep my battery pack fully charged?

Answer: Yes, to maintain your battery performance, please charge your pack every month, even when not using it.

Although our VMS will automatically count cycle use, every charging and discharging, such maintenance charging will be excluded. We recommend you make your battery pack fully charged every time.

5. Shall I connect the final converting board at same ground with the GBTS/PC?

Answer: Yes, please!

The output board must be grounded same as your GBTS/computer system. Therefore, please make this output board connected to the last battery pack, which negative port is connected to the ground of power system.



Application Notes for the VMS and GBTS

6. Does the VMS monitor each cell's voltage?

Answer: Any cell voltage in the whole battery system touching the voltage limit in the pack will enable the OVP (OHV) or LVP (OLV) signal, then output a 5V signal.

7. May I prepare this serial cable by myself?

Answer: **Please don't do it!**

The connecting wire between packs is a dedicated D9 (com-port) wire. Please do not use any D9 wire from retail store. That is because we embed other digital signals (OVP, LVP, and wakeup) to complete the whole controlling system functions.

8. Is the diagnostic program free?

Yes, it's free. But you need a dedicated converter.

9. May I monitor all of battery packs through this GBTS?

Answer: Yes, that is why we use GBTS.

But, we only provide data relative with the packs providing from you. You may check every pack status with our server, on pack level, sub-pack level, or cell level. Basically, we will provide data on pack level only because of data flow. The data we provide will be concluded based on battery knowledge. Therefore, our customers don't need to take care what is the LiFePO₄ battery.

10. Why do I need a GBTS system? I suppose the LiFePO₄ battery is very safe!



Application Notes for the VMS and GBTS

Answer: Yes, the LiFePO₄ battery is much safer than others. But the Lithium battery is still expensive. We prefer to warn, or call our users before the battery gets damaged.

10. Since there is an embedded Win CE, may I use the GBTS as a navigator?

Answer: Not for now!

We reserve a LVDS interface for optional LCD. But due to cost of LCD and software fee, we treat such requirement as a dedicated project.

11. Whether the GBTS is able to perform as a GPS security system?

Answer: Because of personal privacy, the GPS module is optional; it depends on your application. With GPS module, the GBTS is able to track the position of your battery pack, if needed.